

# DJ110 TECHNICAL SPECIFICATIONS



## UNIT DETAILS

Maximum Rec. Continuous Power:	up to 335skW (450shp)
Maximum Rec Impeller speed:	3055rpm
Dry Weight:	175 kg (including standard reverse controls)
Entrained Water:	52 kg (weight of water in pump and inlet duct)
Corrosion Protection:	Cathodic with Anodes
Design Standard:	To international authority standards

## CONSTRUCTION DETAILS

### Impeller:

Diameter:	11 inch (280mm)
No of Stages/Configuration:	Single Stage – Axial / Mixed flow pump
Standard Rotation:	Anti-clockwise (Looking forward from stern)
Impeller Material:	Cast CF8M Stainless Steel

### Pump Assembly:

Impeller Casing Material:	Cast ASTM A356 Alum. Alloy with stainless steel liner
Discharge Nozzle Material:	Cast ASTM A356 Alum. Alloy

### Steering System:

Description	Balanced nozzle
Operation	Inboard tiller actuation
Steering Bowl/Nozzle Material:	Cast ASTM A356 Aluminium Alloy
Nozzle Diameter Range:	145mm - 158mm

### Reverse System:

Description	Split Duct Type – “High Thrust”
Operation	Hydraulic cylinder actuation
Reverse duct material	Cast ASTM A356 Aluminium Alloy

### Shaft Assembly:

Main Shaft Material:	Stainless Steel Grade SAF 2205
Rear Bearing:	Water Lubricated Cutlass Bearing
Main Bearing:	Angular contact Thrust Bearing
Lubrication	Grease
Shaft Seal:	Face type Mechanical Seal
Coupling Flange:	Spicer “1550” Series
Shaft Angle	Available in both 0° (DJ110Z) and 5° (DJ110)

### Intake Body:

Material:	Cast ASTM A356 Aluminium Alloy
Inspection Opening:	Outboard
Intake Grate:	Removable Stainless Steel Bars

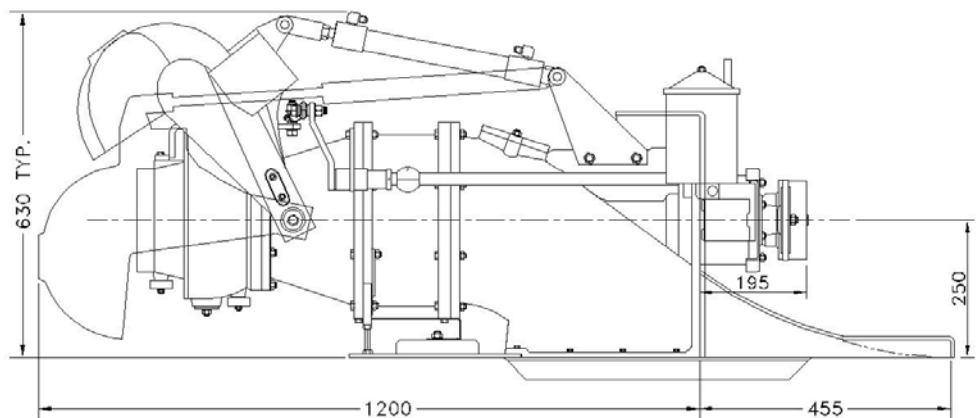
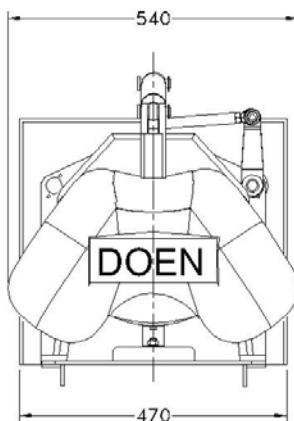

Due to our policy of continuous Research & Development, we reserve the right to change the specifications without notice